



ADVANCED TEMPERATURE CONTROL

WWW.ATC.CA

WWW.ATCTRUCKREFRIGERATION.COM

SERIES 20





ADVANCED TEMPERATURE CONTROL

WWW.ATC.CA

WWW.ATCTRUCKREFRIGERATION.COM

A.T.C. 20 SERIES

SPECIFICATIONS

STANDARD FEATURES

- Engine driven compressor
- ABS (UV) Protected covers
- In-Cab control assembly
- Digital box temperature display
- High/Low pressure protection
- Condenser fan cycle control
- Automatic off cycle defrost control (medium temp)
- Automatic hot gas defrost (low temp)
- 2 HP 230/1/60 Copeland compressor (standby models)
- "POWER PURIFIER" switch mode power supply (standby models)
- Oil separation system (low temp)
- Two piece designed system

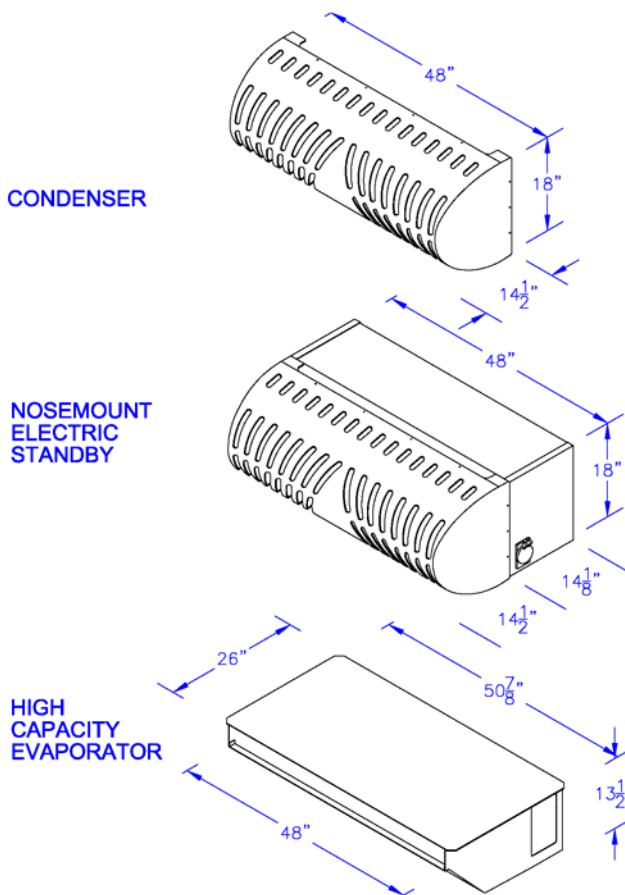

OPTIONAL FEATURES

- Hot water heat
- 12 VDC water pump
- Electric heat
- 230 V.AC 3 phase compressor

CAPACITIES

MODEL	EVAPORATOR RETURN AIR	BTU/HR (WATTS)		WEIGHT	
		IN-TRANSIT	STANDBY	LB	KG
20MA	35F (1.7C)	21,000 (6155)		278	126
20LA	0F (-17.8C)	10,000 (2931)		278	126
20MEA	35F (1.7C)		15,600 (4572)	534	243
20LEA	0F (-17.8C)		6,200 (1817)	534	243

*Capacities and weights are approximate

*Specifications are subject to change without notice

A.T.C offers a one year parts and labour warranty on every refrigeration system.

**FOR ALL YOUR TRUCK REFRIGERATION
REQUIREMENTS " JOIN THE ATC TEAM "**

TEL: (905) 637-3468 FAX: (905) 637-3363